



TRACK AND MAGNETS FOR THE KAT® AUTOMATION CARRIAGE

FLEXIBLE KAT®
TRACK



RIGID KAT®
TRACK



DEEP SECTION
TRACK

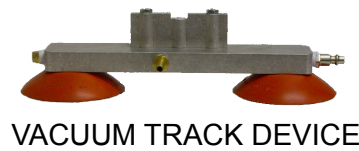

VACUUM TRACK DEVICE



FORMED RING
CLAMP

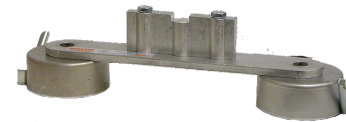

PERMANENT ASSEMBLY



ON / OFF MAGNET ASSEMBLY

A track mounting device for any material

DURABLE TRACK AND MOUNTING DEVICES FOR WELDING AND CUTTING AUTOMATION



GULLCO RIGID KAT® TRACKS

KAT® Track is manufactured in "Standard" and "Deep" sections... each designed to suit a specific range of applications. Both are made to the highest quality levels and incorporate the following top performance features:

PRECISION EXTRUDED ALUMINUM TRACK—made from aluminum that is solution heat treated and artificially aged to produce an alloy having excellent mechanical and corrosion resistant properties. The track is light but strong and the standard section can be readily formed to suit the work contour.

SUPPORTING STEEL RACK—is securely fixed to the KAT® track to provide a smooth, positive drive. The long-life rack easily supports the Kat carriage under maximum load when used in a vertical position.

END DESIGN—enables any two lengths of track to mate accurately and, because of symmetry of design, track lengths can be turned end to end. It is even possible to mate standard and deep track sections.

FAST, EASY JOINING—a dovetail and taper screw that provides accurate location between mating track lengths. The track can be joined in the time it takes to tighten two knurled thumb screws.

VERSATILE MOUNTING—Both standard and deep section tracks have fixing holes on 6" (152.4 mm) pitch along their entire length to provide ample means for mounting or securing brackets.

STANDARD SECTION TRACK

For use with the Gullco KAT® Travel Carriage Model GK-200 in most portable applications. Standard track sections are supplied in 48, 96 and 120 inch (1219, 2438 and 3048 mm) lengths complete with rack and interlocking ends. Standard track can be hard anodized and also formed to desired contours by Gullco or the customer. (see below)

MODEL	LENGTH	LENGTH	
GK-165-052	48" (1219 mm)	GK-165-052-1	96" (2438 mm)
GK-165-054	120" (3048 mm)		

also available up to 20 ft (6096 mm) long-special order

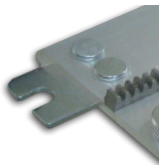

DEEP SECTION TRACK For use with the Gullco KAT® Travel Carriage in applications involving straight permanent runs where greater stiffness is required. Supplied in 60" and 120" (1524 and 3048 mm) lengths complete with interlocking ends. Deep Section Track can also be supplied internally stiffened and hard anodized.

MODEL	LENGTH	LENGTH	
GK-166-258	60" (1524 mm)	GK-166-260	120" (3048 mm)

also available up to 20 ft (6096 mm) long-special order

FORMING STANDARD KAT® TRACK

The following information is provided as a guide to customers ordering Standard Section track preformed to the desired contour by Gullco, or to be formed in their own shop.

1. "Track Datum" always refers to the track surface to which the rack is fixed.
2. When the rack is on the outside of the curve, the "Track Datum Radius" must be greater than 12" (304.8 mm).
3. When the rack is on the inside of the curve, the "Track Datum Radius" must be greater than 24" (610 mm).
4. Always specify whether rack is on the inside or outside of the curve.
5. Standard formed track lengths are 36" (914 mm) and 84" (2133 mm). This is because the first 6" (152 mm) at either end of a track cannot be formed and is therefore removed after bending.

6. When calculating the "Track Datum Radius", allowance must be made for the method of fixing the track to the work. The minimum allowable work to "Track Datum" distance (to permit free movement of the KAT® carriage) is 1-1/2" (38 mm) and when using the standard magnet assemblies this distance is 2-7/8" (73 mm).

KAT® formed track may be held in position by track mounting devices (i.e. magnets, steel brackets tack welded in position, or vacuum cups), or it may be permanently attached to framework alongside the work piece.

If your formed track is of a very permanent nature, it is often advisable to have a section formed and stiffened with welded aluminum side plates. This gives the stiffness of a deep section track in a formed shape. This method is often used in complete ring sections for cutting or welding large diameter pipes.

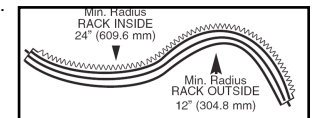

Track Mounting Devices

Shown at right are the Round and Square Magnet devices and steel bracket assemblies used to mount either Gullco Rigid KAT® tracks or Flex-KAT® tracks on ferrous surfaces. Gullco's Vacuum Track Mounting system, described in a separate bulletin, holds KAT® Tracks in position on non-ferrous and ferrous materials.

ROUND MAGNET ASSEMBLIES feature two powerful magnets each with 100 lbs (45 kg.) of holding power and release levers.

SQUARE MAGNET ASSEMBLIES feature magnets each with 75 lbs (34 kg.) of holding power and positive on/off switch. Both of the above assemblies are available as fixed or self-aligning assemblies.

STEEL BRACKET ASSEMBLIES are used with magnet assemblies to provide track stability. They also must be used for added safety, tack welded to the work surface in vertical and overhead welding applications. The four models conform to the heights of assemblies in each of the fixed and self-aligning groups. Standard brackets are mild steel but are available in stainless steel on request.

ROUND MAGNET MOUNTING DEVICES

FIXED

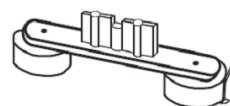

MODEL GK-165-138

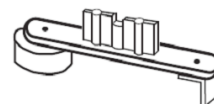

MODEL GK-192-406

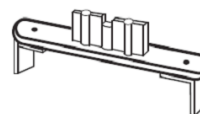

MODEL GK-192-407
Height same as above models

SELF-ALIGNING

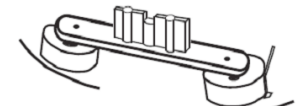

MODEL GK-165-128

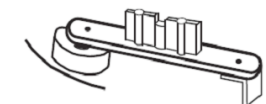

MODEL GK-190-129

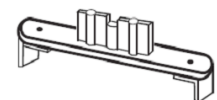

MODEL GK-190-128
Height same as above models

GULLCO KAT® FLEXIBLE TRACK

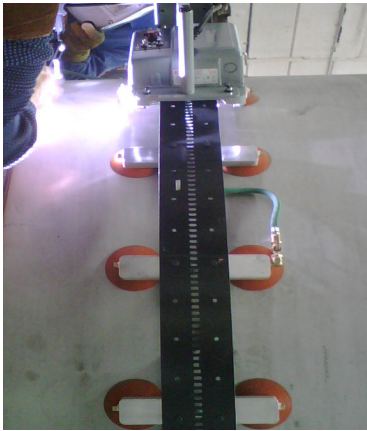

Gullco Heavy Duty "Flexible Track" is specifically designed for use with the Gullco "Flexible KAT® All Position Travel Carriages as shown in application at left. Flexible Track is made from tempered spring steel and can be easily mounted to conform with curved surfaces. This Flexible Track can be used in applications involving curved surfaces 60" (1524 mm) diameter and greater.

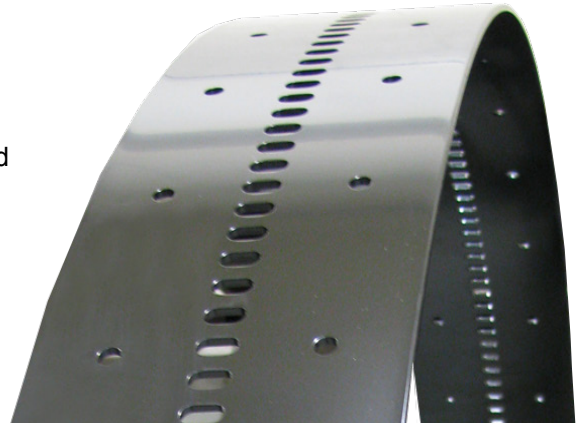

KAT® FLEXIBLE TRACK HEAVY DUTY FLEXIBLE TRACK Model GK-192-F-054-2

Supplied in 8ft. (2438 mm) lengths. Also available in custom lengths up to 8 ft. (2438 mm) with interlocking ends to facilitate complete circles for diameter 60" (1524 mm), O.D. & I.D. and over.

Other lengths available on request.

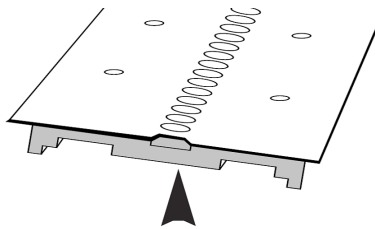

Flexible-Track STIFFENER ADAPTS FLEX-TRACK SECTION FOR USE IN RIGID TRACK APPLICATIONS

Provides extra stiffness and reduces the number of magnet or vacuum track mounting devices required.

MODEL GK-192-F-057

Extruded aluminum stiffener for attachment to Gullco Flexible-Track sections supplied in 8 ft. (2438 mm) lengths.

SQUARE MAGNET MOUNTING DEVICES

FIXED

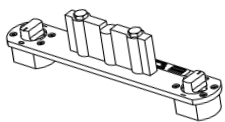

MODEL GK-165-215

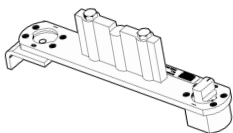

MODEL GK-165-219

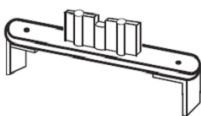

MODEL GK-192-408
Height same as above models

SELF-ALIGNING

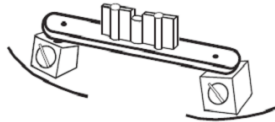

MODEL GK-165-125

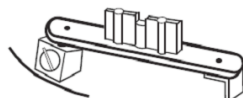

MODEL GK-190-127

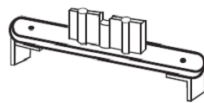

MODEL GK-190-126
Height same as above models

QUICK RELEASE FORMED RING MOUNTING ASSEMBLY

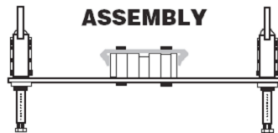

Holds formed "rings" of track in position for pipe welding on non-ferrous and ferrous materials. Heights can be adjusted from 2.8 in. (71.1mm) to 4.95" (125.7mm). Different heights can be achieved using different length 5/16"-18UNC bolts.

KAT VACUUM TRACK MOUNTING SYSTEMS



Holds track in position on non-ferrous and ferrous materials.

PERPENDICULAR TRACK MOUNTING BRACKET Model GK-190-046

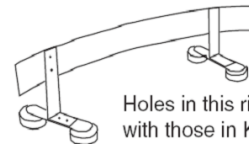

Holes in this rigid steel bracket align with those in Kat Track and support bars on all Gullco track mounting devices...for firm perpendicular mounting of straight or curved rigid Kat Track or Flex-Track sections

PIVOTING TRACK MOUNTING DEVICE Model GK-190-110

Used to mount Gullco Flex-Track in Spherical Tank welding applications to maintain proper welding angle.

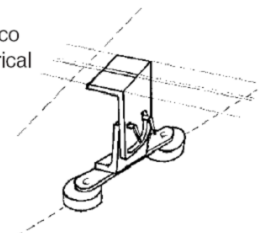

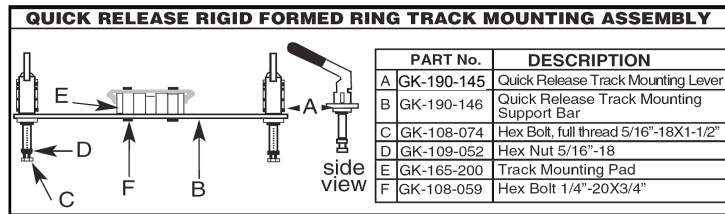
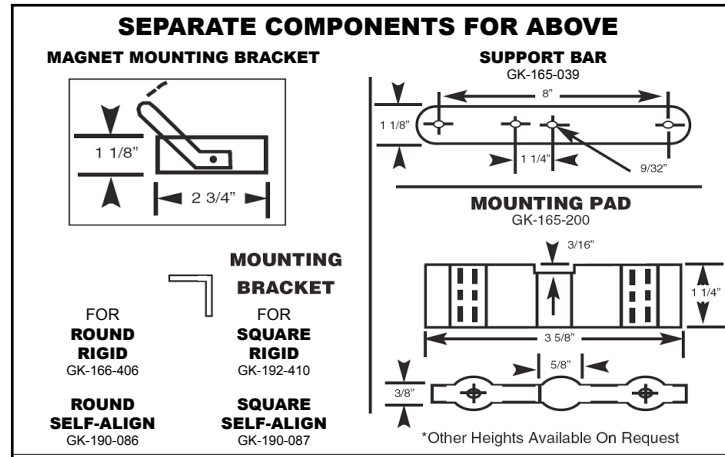
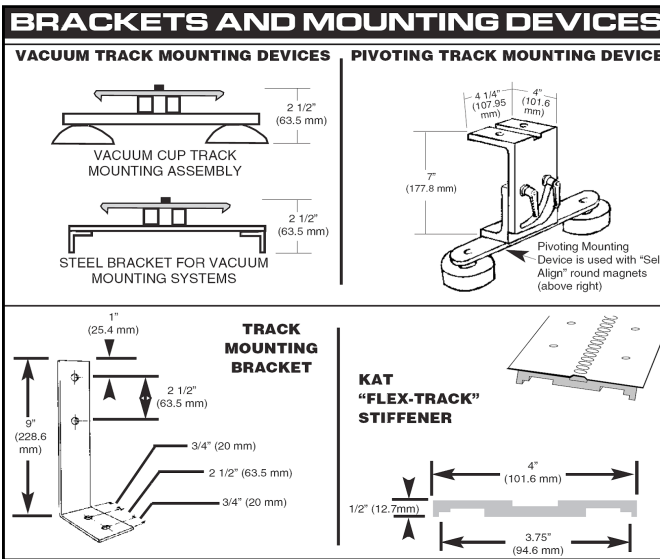
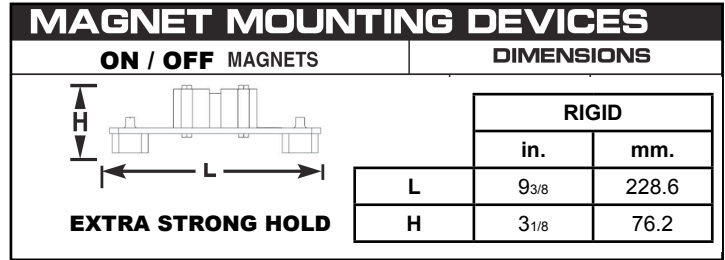
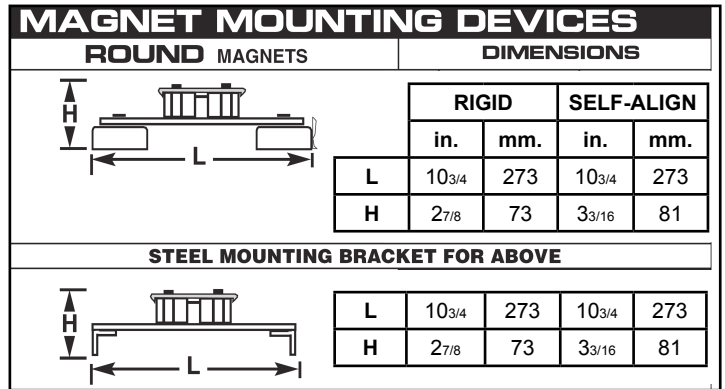
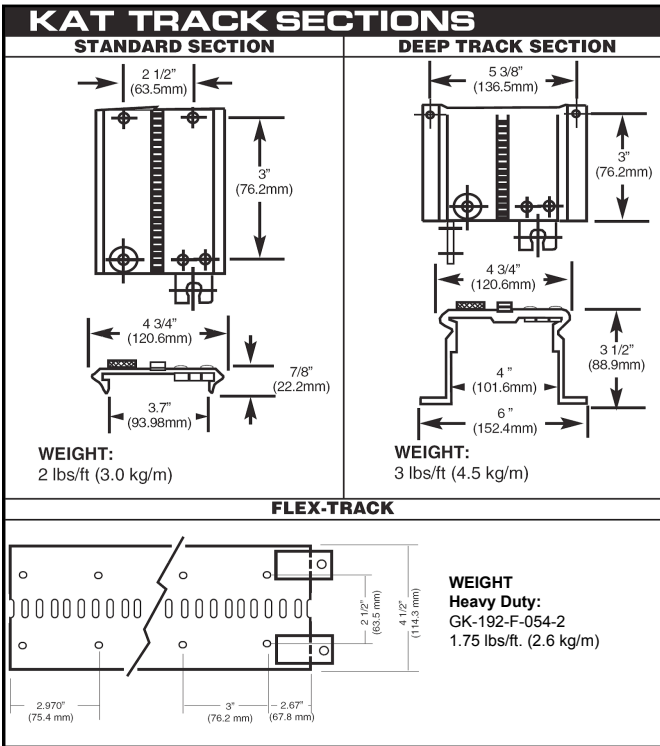

KAT, KBM, MOGGY, KATBAK & SAM are registered trademarks of Gullco Enterprises Limited

SPECIFICATIONS ARE SUBJECT TO CHANGE WITHOUT NOTICE

Distributed by:



Arcent (Singapore) Pte Ltd

2, Yishun Industrial Street 1
Northpoint Bizhub #07-11
Singapore 768159
Tel: +65 6356 6997
Fax: +65 6356 4854

sales@arcentwelding.com
www.arcentwelding.com

WWW.GULLCO.COM

TR-11-01